

VALVULA DE COMPUERTA

VALVULA COMPUERTA HIERRO FUNDIDO
125 LBS. VAPOR - 200 LBS. WOG
VASTAGO ASCENDENTE, BONETE APERNADO

PIEZA	MATERIALES
CUERPO	Hierro fundido ASTM A126 G°B
VASTAGO	Acero al 13% cromo
CUÑA	Anillos de bronce ASTM B62
ASIENTO	Bronce ASTM B62
EMPAQUE	Grafito
VOLANTE	Hierro maleable
EXTREMOS	Flange ANSI B16.5
MARCA	Crane
FIGURA	F58
PROCEDENCIA	Inglaterra

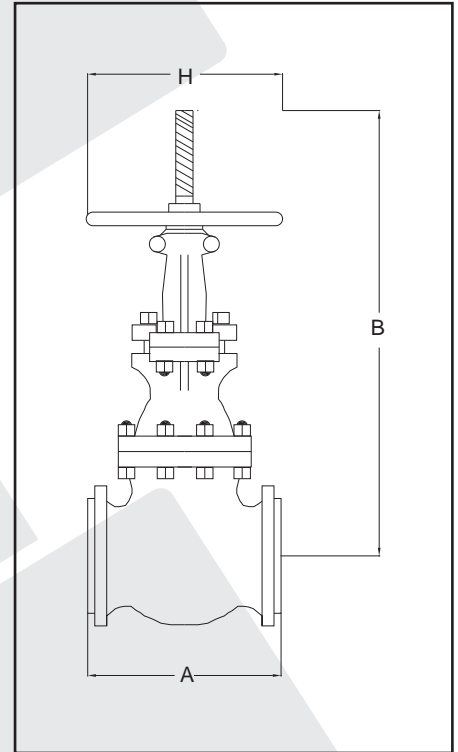

		DIMENSIONES									
MEDIDAS mm	DN	50	65	80	100	125	150	200	250	300	
PESO	Kg.	17	20	28	38	56	60	112	185	242	
DIMENSIONES	A	178	190	203	229	254	267	292	330	356	
	B	365	448	481	622	672	835	989	1208	1469	
	H	152	152	203	229	254	254	305	356	406	

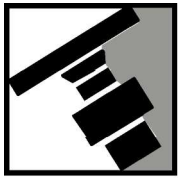

VALVULA COMPUERTA HIERRO FUNDIDO
125 LBS. VAPOR - 200 LBS. WOG
VASTAGO FIJO, BONETE APERNADO

PIEZA	MATERIALES
CUERPO	Hierro fundido ASTM A126 G°B
VASTAGO	Bronce ASTM B62
CUÑA	Anillos de bronce ASTM B62
ASIENTO	Bronce ASTM B62
EMPAQUE	Grafito
VOLANTE	Hierro maleable
EXTREMOS	Flange ANSI B16.5
MARCA	Crane
FIGURA	F53
PROCEDENCIA	Inglaterra

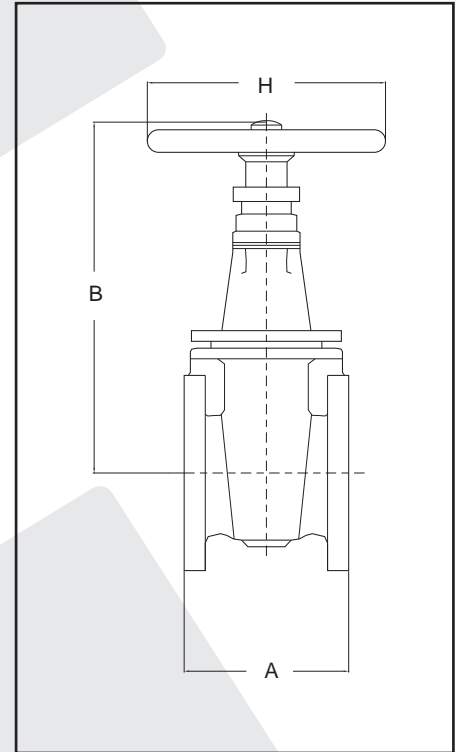

DIMENSIONES										
MEDIDAS mm	DN	50	65	80	100	125	150	200	250	300
PESO	Kg.	12.7	15.8	19.5	29.3	39.5	45.8	84.0	148.0	198.0
DIMENSIONES	A	178	190	203	229	254	267	292	330	356
	B	227	296	337	369	429	470	600	722	818
	H	140	140	152	203	229	229	305	356	406

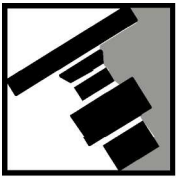

VALVULA DE COMPUERTA

VALVULA COMPUERTA HIERRO FUNDIDO
125 LBS. VAPOR - 200 LBS. WOG
VASTAGO ASCENDENTE, BONETE APERNADO

PIEZA	MATERIALES
CUERPO	Hierro fundido ASTM A 126 G ^o B
VASTAGO	Acero al 13% cromo
CUÑA	Hierro fundido
ASIENTO	Hierro dúctil
EMPAQUE	Grafito
VOLANTE	Hierro maleable
EXTREMOS	Flange ANSI B16.5
MARCA	Crane
FIGURA	F103
PROCEDENCIA	Inglaterra

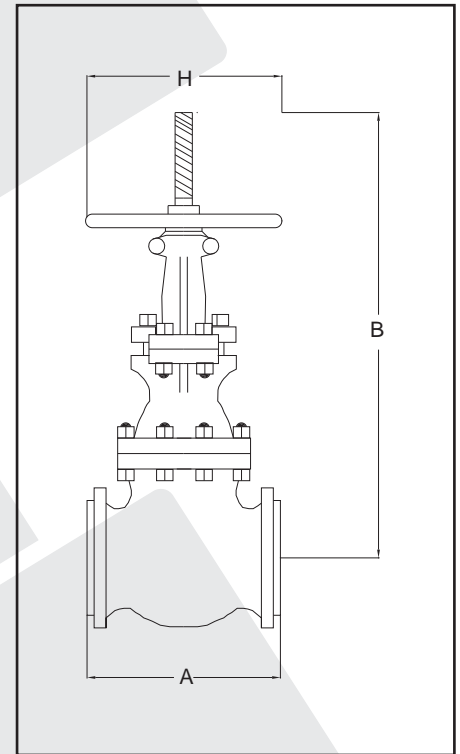

DIMENSIONES										
MEDIDAS mm	DN	50	65	80	100	125	150	200	250	300
PESO	Kg.	20.0	25.4	33.7	52.3	72.3	88.1	140.0	225.0	314.0
DIMENSIONES	A	178	190	203	229	254	267	292	330	356
	B	389	443	492	598	714	813	1013	1257	1454
	H	203	203	229	254	305	305	356	406	457



VALVULA DE COMPUERTA

VALVULA COMPUERTA HIERRO FUNDIDO
125 LBS. VAPOR - 200 LBS. WOG
VASTAGO ASCENDENTE, BONETE APERNADO
LINEA ECONOMICA

PIEZA	MATERIALES
CUERPO	Hierro fundido ASTM A126 G°B
VASTAGO	Bronce ASTM B16
CUÑA	Anillos de bronce ASTM B62
ASIEN TO	Bronce ASTM B62
EMPAQUE	Grafito
VOLANTE	Hierro maleable
EXTREMOS	Flange ANSI B16.5
MARCA	Visa
FIGURA	C5-FB
PROCEDENCIA	China

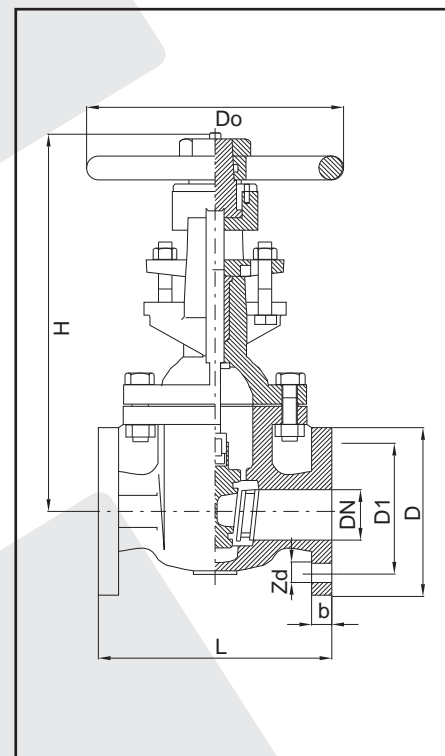

		DIMENSIONES																
DIAMETRO	Pulg.	1 1/2	2	2 1/2	3	4	5	6	8	10	12	14	16	18	20	24	30	36
PESO	Kg.	16	19	26	29	50	71	88	136	214	294	450	580	760	935	1230	2510	3980
DIMENSIONES	L	165	178	191	203	229	254	267	292	330	356	381	406	432	457	508	610	711
	D	127	152	178	191	229	254	279	343	406	483	533	597	635	699	813	984	1168
	D 1	98.6	121	140	152	191	216	241	298	362	432	476	540	578	635	749	914	1086
	b	14.3	16	18	19	24	24	25.4	29	30.2	32	35	36.5	39.7	42.9	47.6	54	60.3
	Z- d	4-16	4-19	4-19	4-19	8-19	8-22	8-22	8-22	12-25	12-25	12-29	16-29	16-32	20-32	20-35	28-35	32-42
	D 0	180	200	200	200	260	300	300	350	400	450	508	558	610	610	762	762	762
	H	290	320	345	387	490	576	680	808	1010	1080	1640	1804	2090	2490	2960	3340	3680

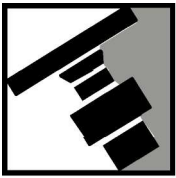

VALVULA DE COMPUERTA

VALVULA COMPUERTA HIERRO FUNDIDO
125 LBS. VAPOR - 200 LBS. WOG
VASTAGO FIJO, BONETE APERNADO
LINEA ECONOMICA

PIEZA	MATERIALES
CUERPO	Hierro fundido ASTM A126 G°B
VASTAGO	Bronce ASTM B16
CUÑA	Anillos de bronce ASTM B62
ASIENTO	Bronce ASTM B62
EMPAQUE	Grafito
VOLANTE	Hierro maleable
EXTREMOS	Flange ANSI B16.5
MARCA	Visa
FIGURA	C1 FB
PROCEDENCIA	China

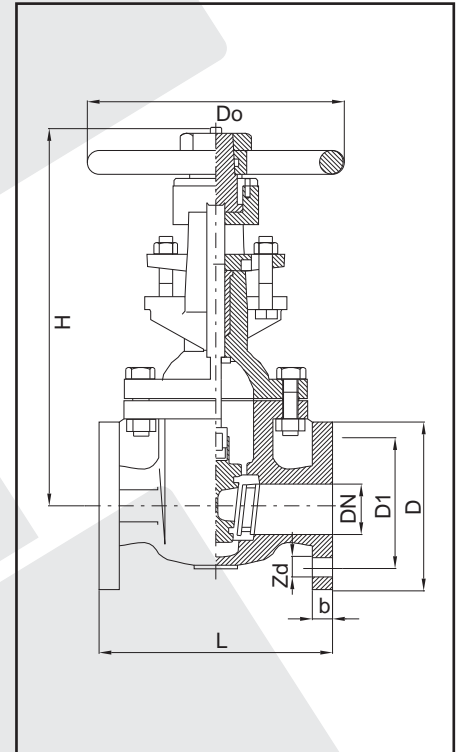

		DIMENSIONES																
DIAMETRO	Pulg.	1 1/2	2	2 1/2	3	4	5	6	8	10	12	14	16	18	20	24	30	36
PESO	Kg.	15	18	25	29	48	65	80	141	202	283	375	497	606	890	1170	2320	3810
DIMENSIONES	L	165	178	191	203	229	254	267	292	330	356	381	406	432	457	508	610	711
	D	127	152	178	191	229	254	279	343	406	483	533	597	635	699	813	984	1168
	D 1	98.6	121	140	152	191	216	241	298	362	432	476	540	578	635	749	914	1086
	b	14.3	16	18	19	24	24	25.4	29	30.2	32	35	36.5	39.7	42.9	47.6	54	60.3
	Z- d	4-16	4-19	4-19	4-19	8-19	8-22	8-22	8-22	12-25	12-25	12-29	16-29	16-32	20-32	20-35	28-35	32-42
	D 0	180	200	200	200	260	300	300	350	400	450	508	558	610	640	640	762	762
	H	280	313	334	370	430	454	550	678	750	880	940	1080	1180	1380	1460	2140	2385



VALVULA DE COMPUERTA

VALVULA COMPUERTA HIERRO FUNDIDO
125 LBS. VAPOR - 200 LBS. WOG
VASTAGO ASCENDENTE, BONETE APERNADO

PIEZA	MATERIALES
CUERPO	Hierro fundido ASTM A126 G°B
VASTAGO	Bronce ASTM B16
CUÑA	Anillos de bronce ASTM B62
ASIENTO	Bronce C83600
EMPAQUE	Grafito
VOLANTE	Hierro fundido ASTM A126 G°B
EXTREMOS	Flange ANSI B16.5
MARCA	Pacific
FIGURA	F125A5
PROCEDENCIA	Mexico

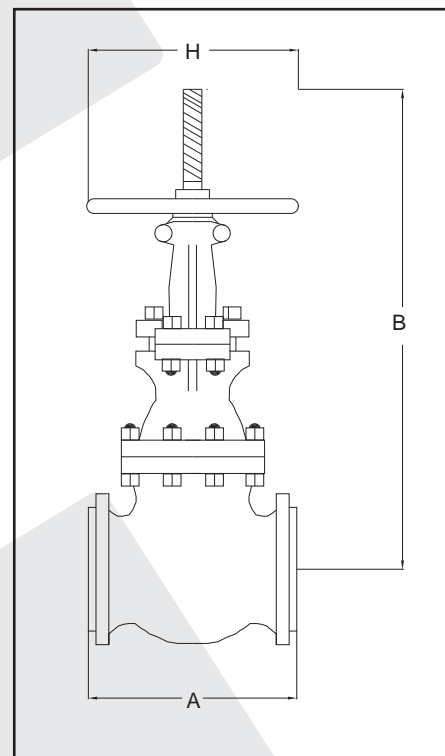

DIMENSIONES										
MEDIDAS mm	DN	50	65	80	100	125	150	200	250	300
PESO	Kg.	17	20	28	38	56	60	112	185	242
DIMENSIONES	A	178	190	203	229	254	267	292	330	356
	B	365	448	481	622	672	835	989	1208	1469
	H	152	152	203	229	254	254	305	356	406



VALVULA DE COMPUERTA

VALVULA COMPUERTA HIERRO FUNDIDO
CUERPO ESTRECHO, DIN PN10
VASTAGO FIJO, BONETE APERNADO

PIEZA	MATERIALES
CUERPO	Hierro fundido GG25
VASTAGO	Bronce ASTM B62
CUÑA	Anillos de bronce ASTM B62
EMPAQUE	Asbesto grafito
VOLANTE	Hierro fundido
EXTREMOS	Flanges DIN PN10/16
MARCA	Varimex o Jafar
FIGURA	011
PROCEDENCIA	Polonia

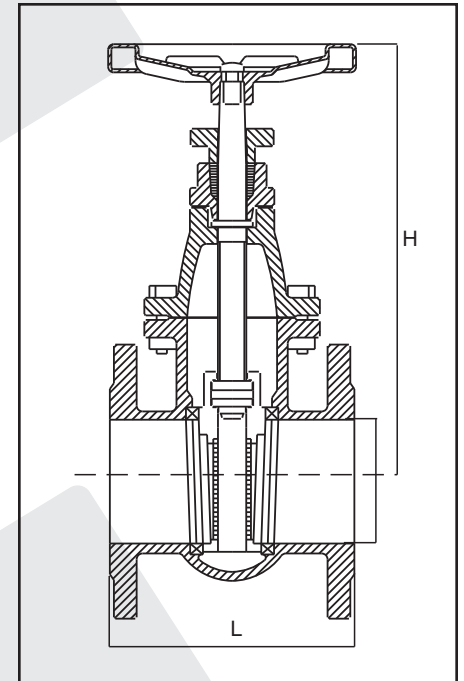

		DIMENSIONES									
DIAMETRO	mm.	1 1/2	2	2 1/2	3	4	5	6	8	10	12
DIMENSIONES	L	140	150	170	180	190	200	210	230	250	270
	F	150	165	185	200	220	250	285	340	395	445
	H	240	245	290	315	355	415	460	545	635	725

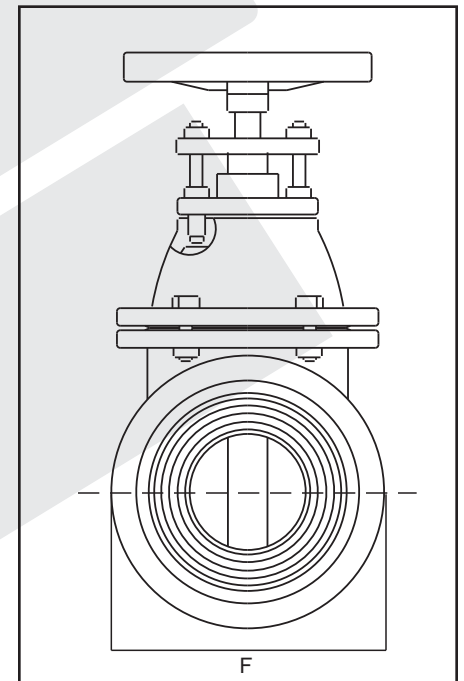

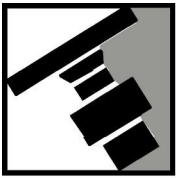

VALVULA DE COMPUERTA

VALVULA COMPUERTA HIERRO FUNDIDO,
CUERPO ESTRECHO, DIN PN10
CIERRE ELASTOMERICO, VASTAGO FIJO, BONETE APERNADO

PIEZA	MATERIALES
CUERPO	Hierro nodular GGG25 o GGG40 revestido con pintura epoxica por electrodeposición
VASTAGO	Acero inoxidable 13% Cromo
CUÑA	Hierro nodular GGG25 o GGG40, revestida con EPDM
EMPAQUE	EPDM
VOLANTE	Hierro fundido
EXTREMOS	Flanges DIN PN 10/16
MARCA	Jafar
FIGURA	111 P
PROCEDENCIA	Polonia

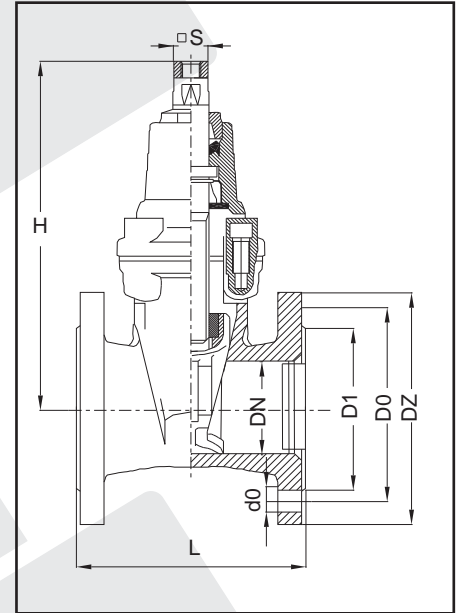

		DIMENSIONES									
DIAMETRO	Pulg.	1 1/2	2	2 1/2	3	4	5	6	8	10	12
PESO	Kg.	9	9.7	11.7	18	25.9	32.9	45.6	62.3	89.2	119.6
DIMENSIONES mm	DN	40	50	65	80	100	125	150	200	250	300
	L	140	150	170	180	190	200	210	230	250	270
	H	233	240	277	300	339	376	438	512	611	686
	D1	88	102	122	138	158	188	212	268	320	378
	Dz	150	165	185	200	220	250	258	340	405	460
	Do	110	125	145	160	180	210	240	295	355 (350)	410 (400)
	do	18	18	18	18	18	18	22	22	26 (22)	26 (22)
		4	4	4	8	8	8	8	12 (8)	12	12
	S	14	14	17	17	19	19	24	24	27	27